

Standard Construction and Materials

FRAME: .081" thk. (nominal) extruded aluminum, 6063-T52/T6 alloy. Channel type.

BLADE: .081" thk. (nominal) extruded aluminum 6063-T52/T6 alloy. Blades are approximately 4½" on centers.

LOUVER FACE: Full width sill with drain head and drain blades contained within drain jambs.

SHAFT: .50" dia aluminum "Pin-Lock" rod.

BEARINGS: Celcon bearing material so that there will be no metal to metal friction.

LINKAGE: Extruded aluminum, concealed in the channel out of the airstream. The pivots, which rotate in Celcon bearings, are .50" dia. plated and machined steel. The pivot is locked to the 9/16" dia. aluminum linkage rod by a ¼ - 20 set screw with epoxy locking patch.

SEALS: Extruded silicone rubber seals at blade edge. Polyurethane at jambs.

SCREEN: (When indicated, in a removable frame)

½" flattened aluminum, .051" thk.,

-or- ½" sq. mesh intermediate double crimped aluminum wire, .063" dia.,

-or- 18/16 aluminum mesh insect screen, .011" dia.

FINISH: Mill.

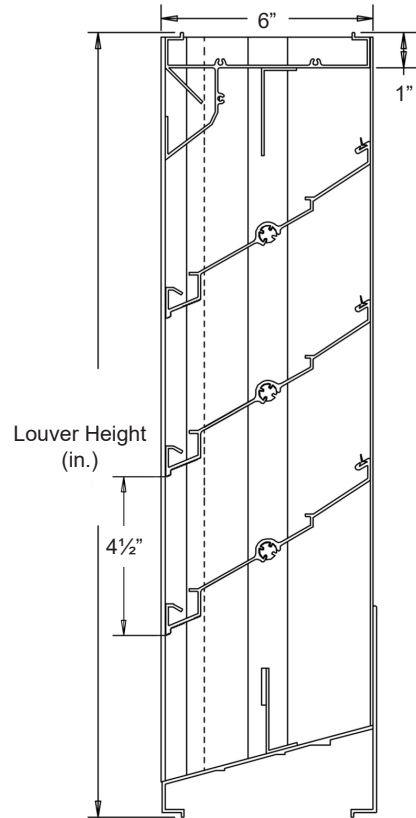

Not to scale.

Options

Finishes - Enamels, Epoxies, etc.

Other screens also available.

Actuators - Electric, Pneumatic, Manual, etc.

Notes

1. Nominal deductions will be made to the opening size given.

2. Approximate shipping weight is 5.6 lbs./sq.ft.

Louver Sizes

Min Panel	Max Single Panel
12"W x 12"H	48"W x 96"H

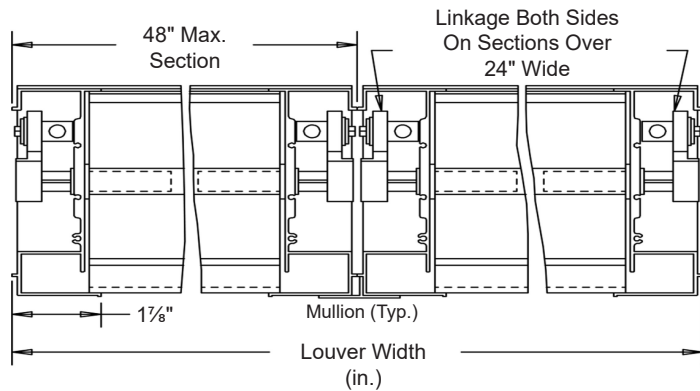
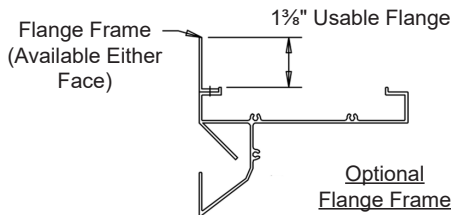

Item #	Qty	Width	Height	Width	Height	Mullion	Type	Location		
Arch. / Eng.:		Opening Size		Louver Size		EDR:	Screens		ECN:	Job:
Contractor:						Date:	DWN:	DWG:		

In the interest of product development, Cesco Products reserves the right to make changes without notice.



450 Riverside Dr • Wyalusing PA, 18853
 Phone: 570-746-1888 • Fax: 570-746-9286
 www.cescoproducts.com

Performance Data

Pressure Drop: .145 in. w.g. at 1000 fpm (intake)

Free Area: 8.58 sq.ft. = 54% for 48"W x 48"H sample tested in accordance with AMCA Standard 500-L.

Beginning Point of Water Penetration: 880 fpm

Ratings do not include the effects of a screen.

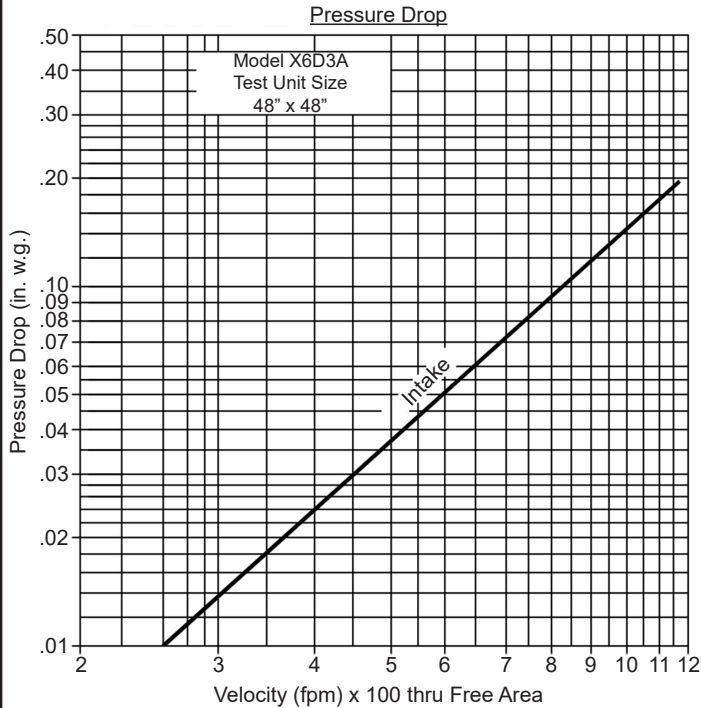

Intake air converted to standard air density.
Tested to AMCA Standard 500-L, Figure 5.5.

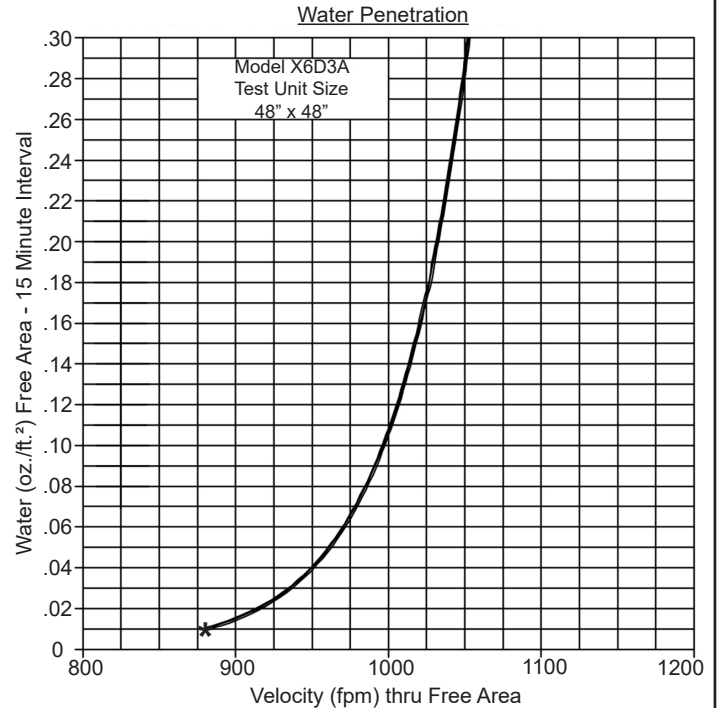

880 (FPM) Beginning Point of Water Penetration.

Free Area (sq. ft.)

		Width (in.)						
		12"	18"	24"	30"	36"	42"	48"
Height (in.)	12"	.21	.36	.51	.67	.82	.98	1.13
	24"	.53	.93	1.33	1.73	2.13	2.53	2.93
	36"	1.02	1.79	2.56	3.32	4.09	4.86	5.62
	48"	1.51	2.65	3.78	4.92	6.05	7.19	8.58
	60"	1.84	3.22	4.60	5.98	7.36	8.74	10.12
	72"	2.33	4.08	5.82	7.57	9.32	11.07	12.81
	84"	2.82	4.93	7.05	9.16	11.28	13.39	15.51
	96"	3.15	5.51	7.87	10.23	12.59	14.95	17.31